



ULTRA PRECISION CUTTING TOOLS

WAVINESS CONTROLLED TOOLS

WAVINESS CONTROLLED
轮廓度控制

WAVINESS CONTROLLED TOOLS

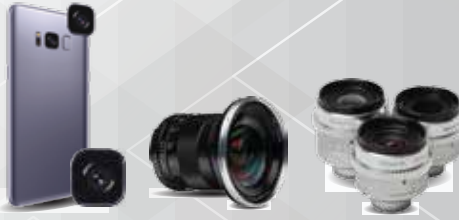

为了更好的商品制造匠心工具
ALL ABOUT WAVINESS CONTROLLED TOOLS





目次

about SINJIN		生产设备一览及检测仪器		检测报告		产品跟踪管理		技术研究所及技术交流		组织图
4		6		8		9		10		11

ABOUT SINJIN

超过天然金刚石的界限

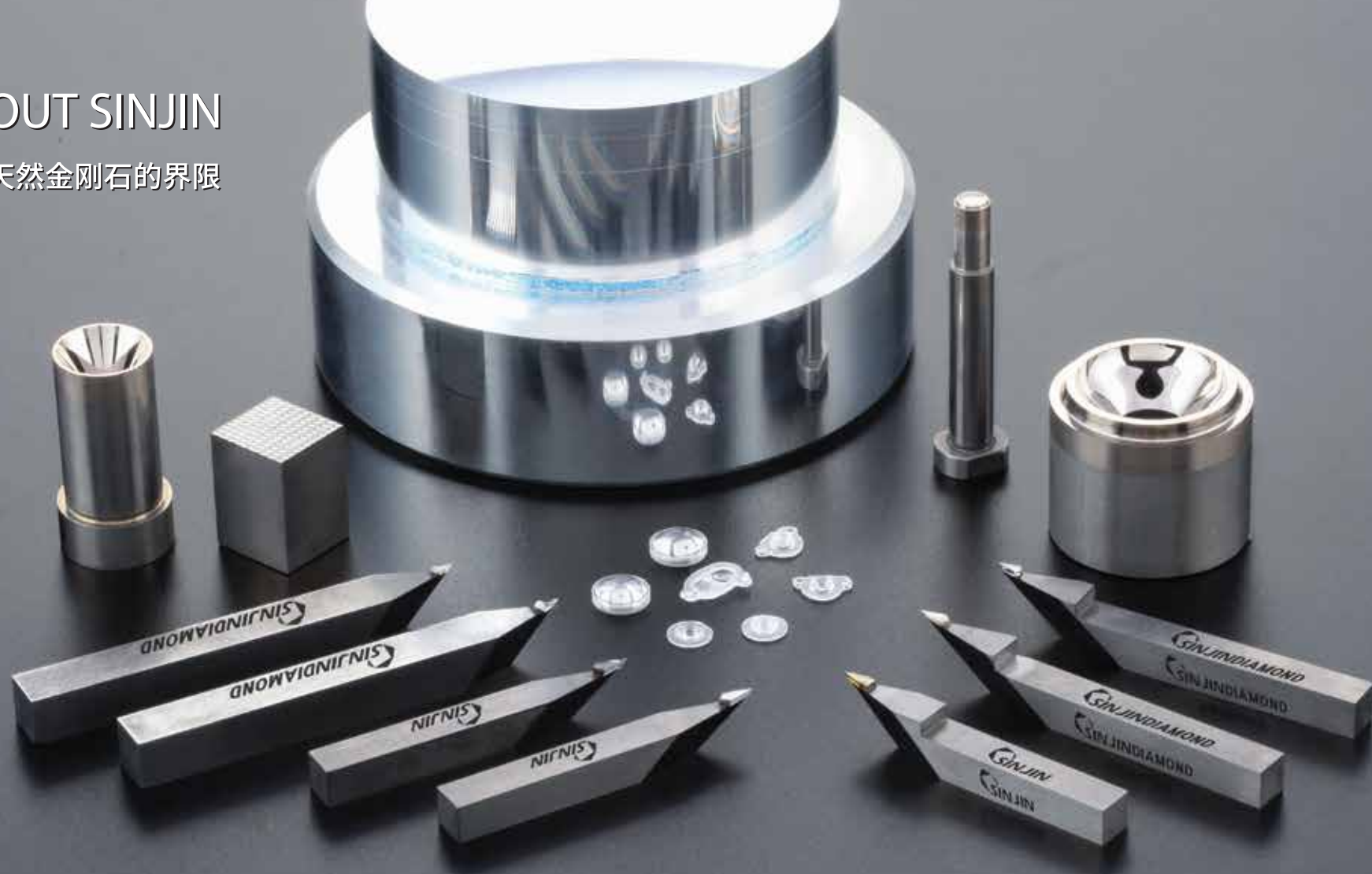

ALL QUALITY ARE PERFECT QUALITY

为了加工精密的镜头磨具, 制造和供应超精密钻石刀具。

- 
- 1977** 新进金刚石工业公司创立
 - 2004** 开发LCD导光板棱镜膜刀具
 - 2006** 开发LED 蓝宝石晶片切削用的刀具
产业资源部部长表彰
 - 2007** 企业技术研究所成立
开发超高速打印用 以及医用金刚石手术刀
 - 2009** 开发光学镜片加工模仁用波纹度50nm刀具
开发微米图案加工用 纳米级铣刀
 - 2010** 开发3D 显示器微结构刀具
 - 2015** 中国烟台分公司创立
 - 2017** 环境经营系统认证书(ISO 14001:2015)
品质经营系统认证书(ISO 9001:2015)
 - 2018** 各项目原产地认证出口商认证

1mm

0.1mm

0.01mm

0.001mm

0.00005mm

1997

2004

2007

2009

2017

生产设备一览及检测仪器

拥有世界领先的天然金刚石刀具技术

天然金刚石加工设备



测量设备



NATURAL DIAMOND

以先进的技术实力,跨进新时代



OPTICAL LENS / MOBILE CAMERA LENS / VR LENS / BLACK BOX LENS / ETC



Waviness Controlled

检测报告

超过微米, 达到纳米级



精刀 形状精度 50纳米以下

Item	Specification	Measurement
Radius	47.0 ~ 51.0µm	50.9µm
Waviness	≤ 50nm	20nm
Tool Height		9.047mm
H1	≤ 0.12mm	0.11mm
Included Angle	30°	30°
Window Angle	120°	120°
First Clearance	15°	15°
Second Clearance	45°	45°
Rake Angle	0°	0°
A		



粗刀 形状精度 50纳米以上

Item	Specification	Measurement
Radius	47.0 ~ 51.0µm	50.3µm
Waviness	50nm ≤	60nm
Tool Height		9.058mm
H1	≤ 0.12mm	0.12mm
Included Angle	30°	30°
Window Angle	120°	120°
First Clearance	15°	15°
Second Clearance	45°	45°
Rake Angle	0°	0°
A		

* 这是企业提供的部分实际检测报告

产品跟踪管理

使用差别化的系统, 进行产品跟踪管理

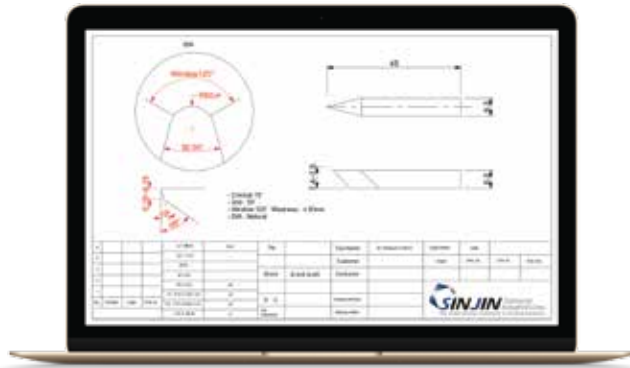

制造定制刀具

制造定制刀具时, 按客户要求制图, 投产

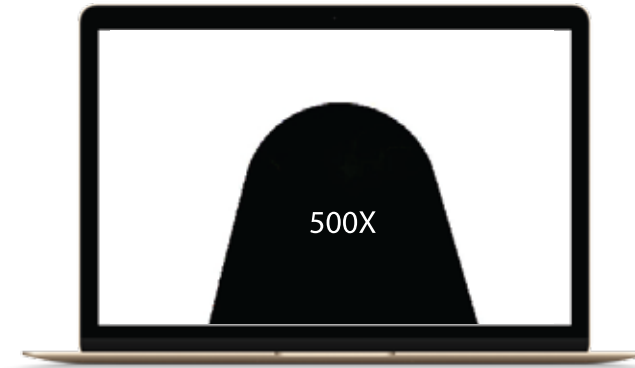

精密检测

每次产品出库时, 用最高端显微镜进行纳米级无瑕疵检测



准确的产品跟踪管理

使用自主开发的产品跟踪管理系统, 更准确的管理产品履历



严格的品质管理

针对维修的刀具, 先比较分析之前数据参数, 执行严格的品质管理

技术研究所及技术交流

实现21世纪纳米科技

新进金刚石工业技术研究所



新材料研发

(汉阳大,韩国生产技术研究院)

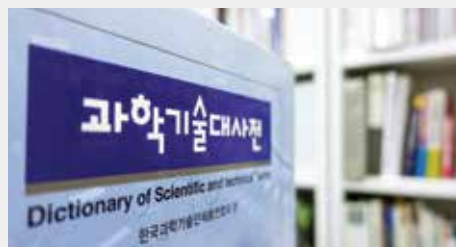

切削加工时动态性能机制的研究

(韩国基础科学支援研究院)



Waviness Tool 及 辘轮加工用刀具加工性能测试

(忠南显示屏中心)



海外技术交流

(与英国Chase 共同研发)

产·学·研 合作研究活动



超精密金刚石刀具制造工艺技术研发及切削加工动态特性研究

INDUSTRY UNIVERSITY INSTITUTE COLLABORATION

组织图

新进金刚石 组织图





SINJINDiamond

HEAD OFFICE / R&D CENTER, KOREA(韩国总公司)

SINJIN B/D, 22, Yangpyeong-ro 12-gil, Yeongdeungpo-gu, Seoul, 07222, Korea
TEL : +82 2 2635 1951 FAX : +82 2 2675 3976 E-MAIL : sales@sinjindia.com
HOMEPAGE : www.sinjindia.com

中国办事处(烟台)

新进金刚石科技(烟台)有限公司
地址:山东省烟台市经济技术开发区长江路150号910
TEL : +86 535 610 7334 E-MAIL : sinjindia@163.com HOMEPAGE : www.sinjindia.com/cn

中國總代理商(大連)

大連金海大元貿易有限公司
地址:遼寧省大連市金州區斯大林路碧海尚城2號樓
TEL : +86 0411 8802 8697 HP : +86 186 6649 0603 E-MAIL : jinhaidayuan@163.com

