

1278nm DM LASER

EP1278-DM-B

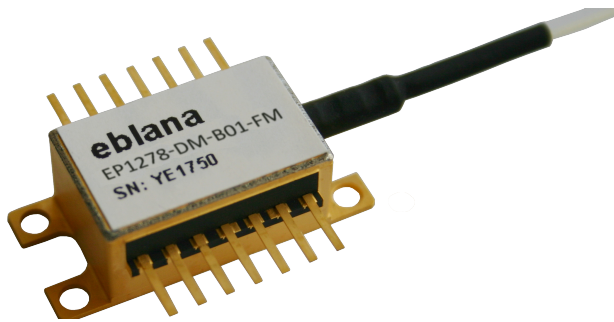

eblanaphotonics



PRECISION HF SENSING

Eblana Photonics EP1278-DM-B laser diode, available at a range of wavelengths from 1260 - 1288nm, is designed specifically for detection of Hydrogen Flouride. Eblana's Discrete-Mode (DM) technology enables cost effectiveness with mode-hop free tunability and excellent SMSR.

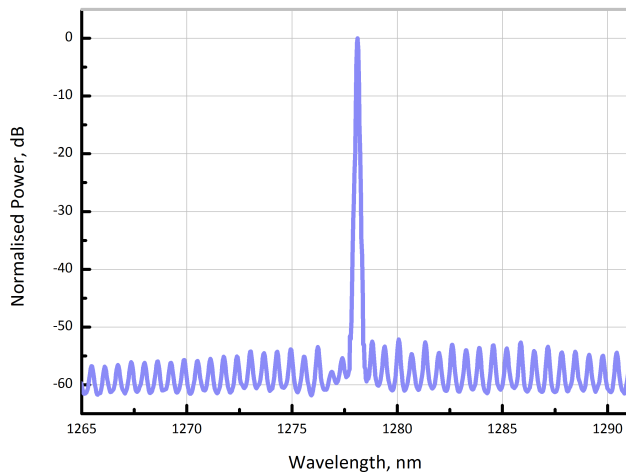

Optical Spectrum at 25°C

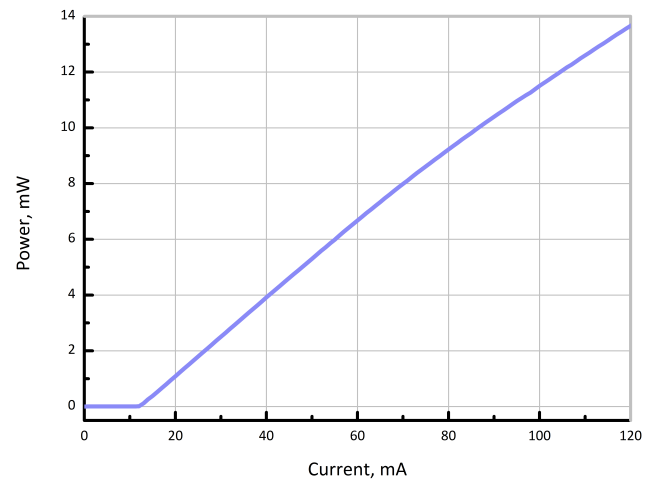

Output power as a function of bias current.

ELECTRO-OPTICAL CHARACTERISTICS* ($T_{SUB} = 25^{\circ} C$)

PARAMETER	SYMBOL	MIN	TYP	MAX	UNIT
Centre Wavelength Range	λ	1260	1278	1288	nm
Wavelength specification	λ_{spec}	$\lambda - 1$	λ	$\lambda + 1$	nm
Side Mode Supression Ratio	SMSR	30	40	-	dB
Threshold Current	I_{th}	-	15	20	mA
Output Power in fiber	P_f	5	8	12	mW
Optical linewidth	Δf	-	-	2	MHz
Temperature Tuning Coefficient	T_{λ}	0.07	0.1	0.14	nm/°C
Current Tuning Coefficient	I_{λ}	0.008	0.014	0.020	nm/mA
Slope Efficiency	SE	0.1	0.15	-	mW/mA
Thermistor Resistance	R_T	9.5	10	10.5	k Ω
Thermistor Temp. Coefficient	C	-	-4.4	-	%/°C

*CW bias unless otherwise stated

©Eblana Photonics Series 1278-DM-B Rev 2.0



eblanaphotonics

www.eblanaphotonics.com

Sales@eblanaphotonics.com

Dublin, Ireland

ABSOLUTE MAXIMUM RATINGS

PARAMETER	SYMBOL	MIN	TYP	MAX	UNIT
Forward Current	I_f	-	80	120	mA
Forward Voltage	V_f	-	1.3	1.6	V
TEC Current	I_{TEC}	-	0.5	1.2	A
Reverse Voltage LD	V_r	-	-	2.0	V
Reverse Voltage PD	V_{rev}	-	-	20	V
Case Temperature*	T_{Case}	-20	-	65	°C
Chip Submount Temperature	T_{Sub}	0	-	50	°C
Storage Temperature	$T_{storage}$	-40	-	85	°C

*For $T_{sub} < 25^{\circ}C$, Max Case Temperature should be derated to $T_{Case,Max} = T_{sub} + 40^{\circ}C$

PACKAGING

The EP1278-DM-B product series is offered in a 14-pin Butterfly package - Inquire for other packaging options. The standard package pinout is shown below, variations may be requested.

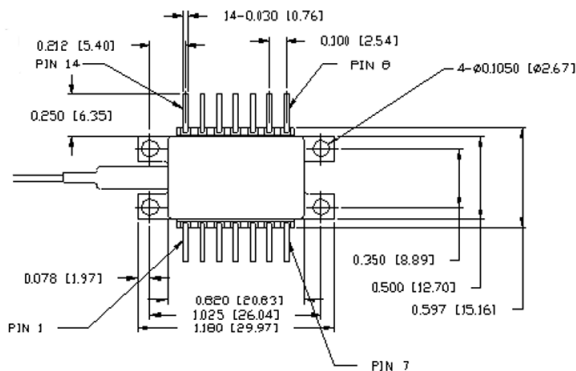

14-pin butterfly schematic

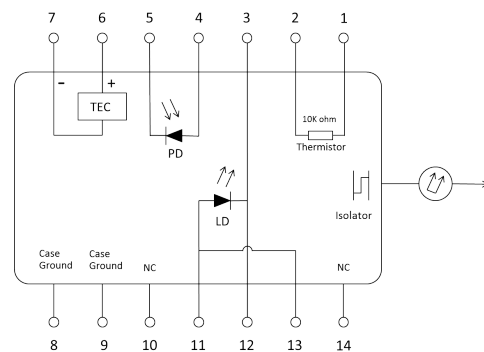

Standard "Pinout 01" option

HOW TO ORDER

Construct your part number using the following example and email your order to sales@eblanaphotonics.com, or call +353 1 675 3228.

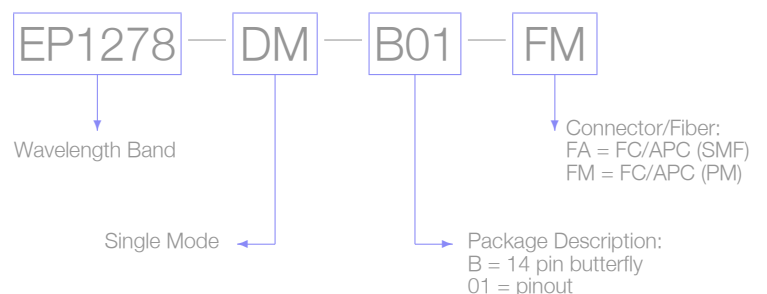

Laser Safety

This is a Class 3R Laser Product as defined by International Standard IEC 60825-1, Edition 2. Invisible Laser radiation is emitted from the end of the fiber or connector. Avoid direct eye exposure to the beam. Laser safety labels are not attached to the module due to space limitations but instead are affixed to the outside of the shipping carton.

©Eblana Photonics 2013. Eblana Photonics Reserves the right to amend this document at any time, without prior warning. ©Eblana Photonics Series 1278-DM-B Rev 2.0