

# KeyEGB-3000-A1 Fiber Laser Galvo Laser Edge Banding Unit

Spec 1001 Rev. A

### Features

- Compact
- User-friendly Interface
- Proprietary Locking Method of QBH

### Applications

- Furniture
- Woodworking

### Specifications

Parameter	Unit	Value
Laser Power	W	≤ 3000
Operating Wavelength	nm	1080 ± 10
Numerical Aperture (NA)	-	≤ 0.11
Beam Size	mm	5 ± 1
Beam Offset	mm	± 10
Edge Banding Width	mm	10 ~ 60
Working Distance	mm	400 ± 100
Speed	m/min	≤ 25
Compatible Interface	-	QBH
Hose Diameters (ID / OD)	mm	4 / 6
Weight	kg	≤ 2.1
Operating Temperature	°C	0 ~ 45
Storage Temperature	°C	-20 ~ 70

### Dimensions

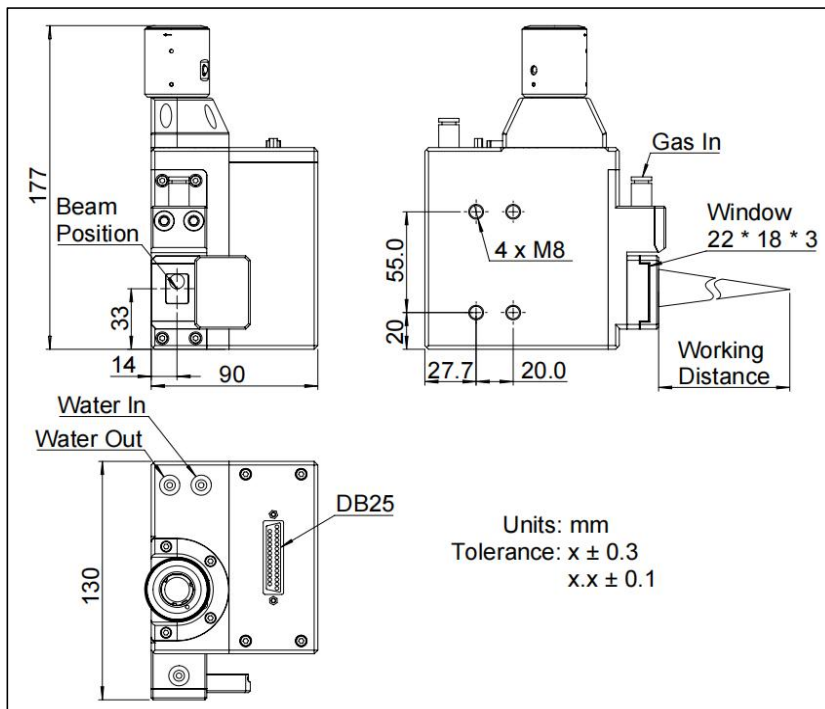

### Ordering Information

KeyEGB-3000-A1