

KeyEGB-3000-A2 Diode Laser Galvo Laser Edge Banding Head

Spec 1002 Rev. A

Features

- Compact
- User-friendly Interface
- Proprietary Locking Method of QBH

Applications

- Furniture
- Woodworking

Specifications

Parameter	Unit	Value
Laser Power	W	≤ 3000
Operating Wavelength	nm	976 ± 5
Numerical Aperture (NA)	-	≤ 0.22
Beam Size	mm	5 ± 1
Beam Offset	mm	± 10
Edge Banding Width	mm	10 ~ 60
Working Distance (WD)	mm	300 ± 50
Speed	m/min	≤ 25
Compatible Interface	-	QBH
Hose Diameters (ID / OD)	mm	4 / 6
Weight	kg	≤ 2.1
Operating Temperature	°C	0 ~ 45
Storage Temperature	°C	-20 ~ 70

Dimensions

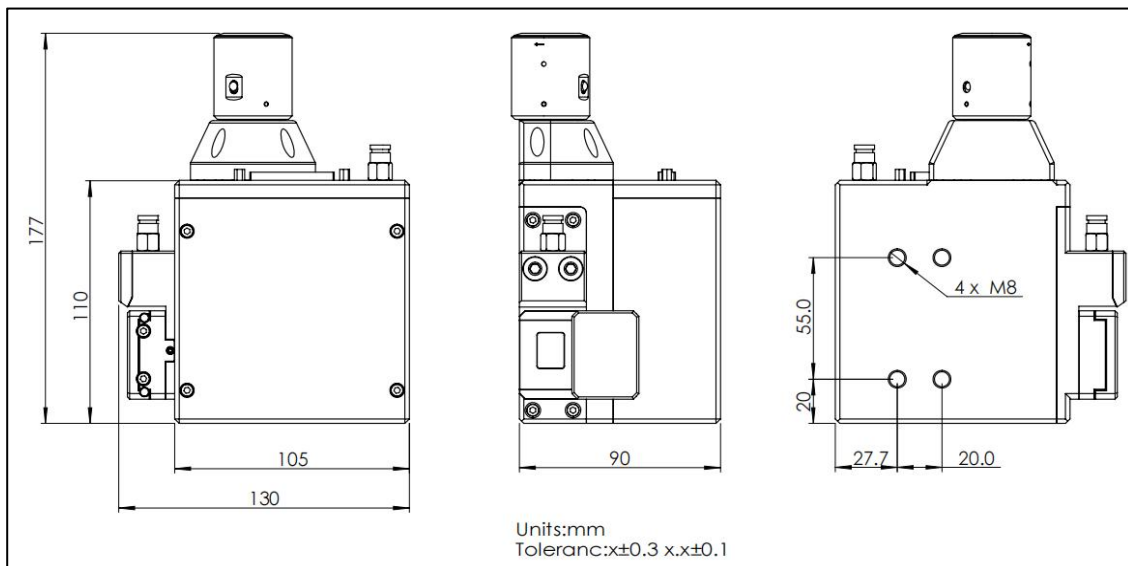

Ordering Information

KeyEGB-3000-A2