

## KeyCol-3000-A1 Collimating Unit

Spec 1005 Rev. A

### Features

- Water Cooled
- Factory Aligned
- Proprietary Locking Method of QBH

### Applications

- Industrial Laser Processing
- Scientific Research

### Specifications

| Parameter                      | Unit  | Value      |
|--------------------------------|-------|------------|
| Laser Power                    | W     | ≤ 3000     |
| Operating Wavelength           | nm    | 900 ~ 1000 |
| Numerical Aperture (NA)        | -     | ≤ 0.22     |
| Focal Length                   | mm    | 60         |
| Compatible Interface           | -     | QBH        |
| Flow Rate                      | L/min | ≥ 1        |
| Water Pressure                 | Mpa   | ≤ 0.6      |
| Water Hose Diameters (ID / OD) | mm    | 4 / 6      |
| Weight                         | kg    | ≤ 0.65     |
| Operating Temperature          | °C    | 0 ~ 45     |
| Storage Temperature            | °C    | -20 ~ 70   |

### Dimensions

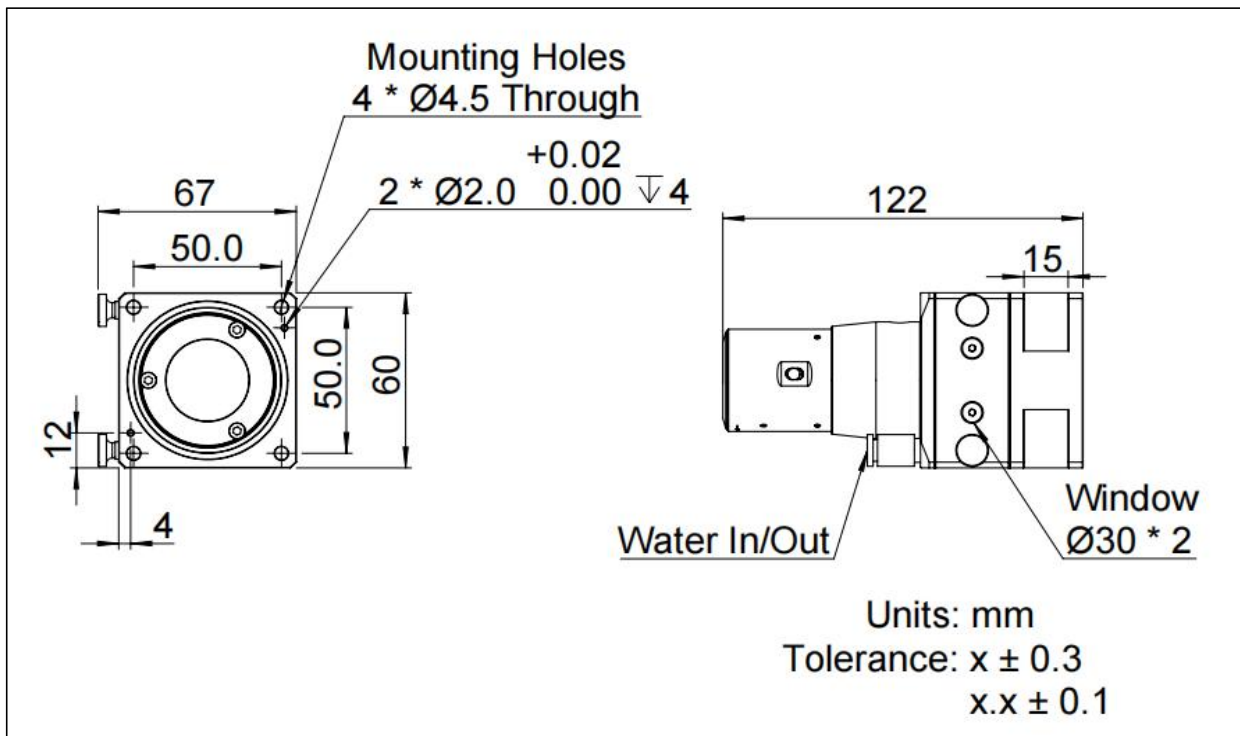

### Ordering Information

KeyCol-3000-A1